

DORMA GLAS

HSW-DRS Sliding Glass Walls

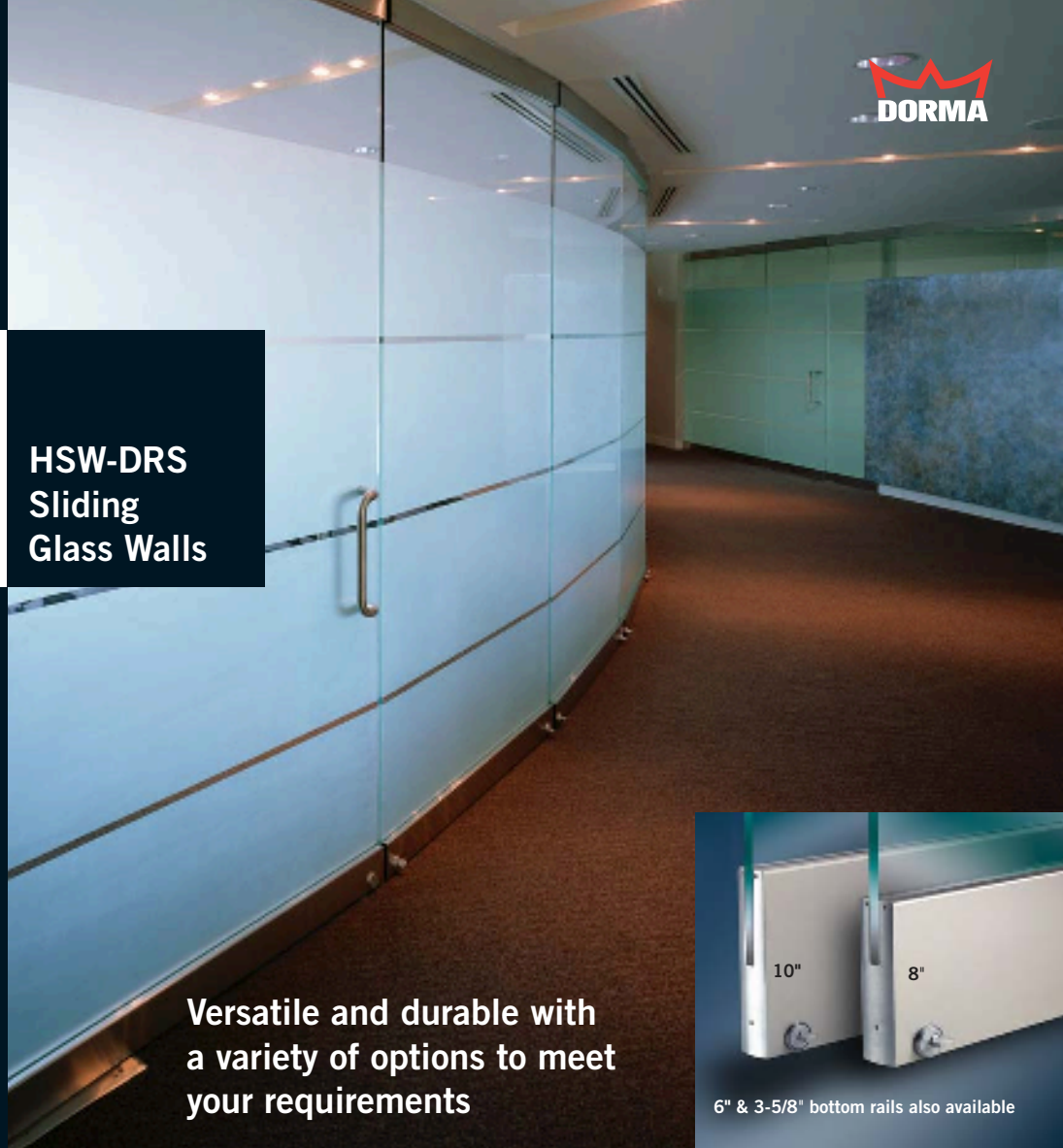

Versatile and durable with a variety of options to meet your requirements



6" & 3-5/8" bottom rails also available

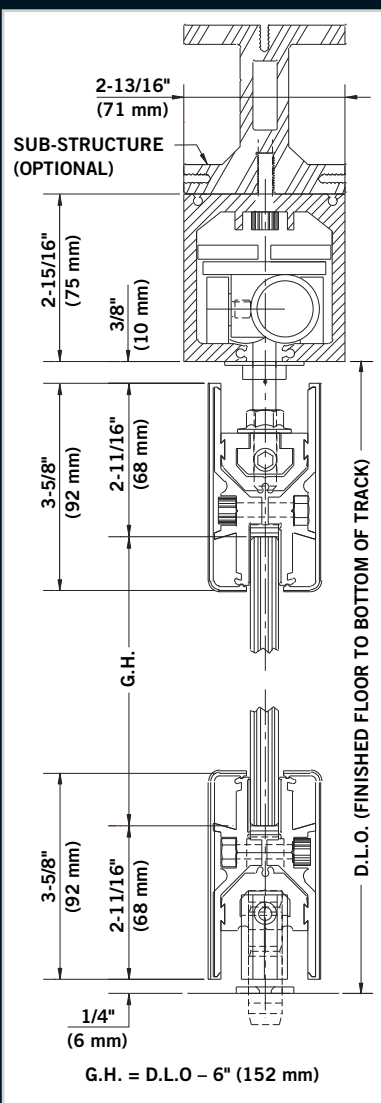

Innovative designs mean that HSW-DRS Sliding Glass Walls have the features needed to meet the most demanding requirements.

- Suitable for both inline and curved configurations.
- Snap-on covers that are interchangeable in the field.
- Mechanical clamp-on system.
- System available with vertical stiles.
- No floor track.
- All rail sizes available for 3/8" and 1/2" (10 and 12 mm) glass.
- 3-5/8" rails available for 3/8", 1/2", 5/8", and 3/4" (10, 12, 16, and 19 mm) glass.
- Bottom rail available in 3-5/8", 6", 8", and 10" (92, 152, 203, and 254 mm) heights.
- Doors can be prepared for a full range of DORMA architectural hardware.

Panel Limits:

- Max Height 120" (3000 mm)
- Max Weight 300 lb (136 kg)
- Min Width 24" (600 mm)
- Max Width 42" (1060 mm)

Standard Finishes:

- Clear Anodized
- Dark Bronze Anodized
- Black Anodized
- Satin Stainless
- Polished Stainless
- Satin Brass
- Polished Brass

Custom Finishes:

- Powder Coated RAL Painted Finishes

Lead Time:

- 5 weeks. System Fabricated in US.

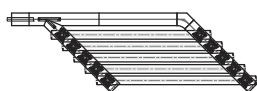

135° Parallel Stack

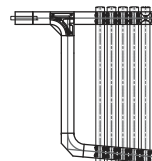

90° Perpendicular Stack

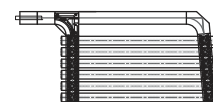

90° Parallel Stack

DORMA Glas HSW Sliding Glass Walls

The DORMA Substructure

The new DORMA substructure system is of modular construction and is designed to significantly reduce on-site installation cost and time. This concept also offers the particular flexibility required to overcome structural constraints, such as the presence of air conditioning shafts or pre-existing electrical systems in the ceiling.

The DORMA substructure consists primarily of the following components: substructure profile with modules for branching to the stacking area, threaded rods for suspension of the profile(s), and standard square section tubes with appropriate fixings and ceiling brackets for bracing and stiffening the construction.

Various bolting channels run the whole length of the profile, allowing bolts to be inserted easily at any location within the system configuration. So there is no need for pre-drilling and thread cutting in order to mount the track rails onto the substructure.

Bolting channels on both sides of the profile can be used, e.g. for fixing the brackets needed for attaching the ceiling retention elements.

Depending on the weight of the system and the permitted deflection, it is possible to

span a distance of up to 117" (3 m) between 2 suspension points.

Standard flat steel bars can be inserted in the center channel to further stiffen the profile, particularly in the area of the joints. This means that just one suspension point in the vicinity of the joint can be provided instead of the two—one either side of the joint—that are usually needed.

With a maximum load (panel weight) of 330 lb (150 kg) and a permitted deflection of the substructure with track rail of 1/8" (3 mm), the interval between 2 suspension points must be no greater than 117" (3 m). The diagram *Example Load Values* shows other values for different loads.

The individual components are coordinated to ensure safe integration. Joints in the substructure are offset to those in the track rails so that individual joints coincide with continuous material in all cases.

Provided that the track rails are adequately bolted to the substructure, gaps of up to 11" (279 mm) in straight runs and 5" (127 mm) in stacking areas measured from one suspension point to the next are permitted in the substructure.

The System

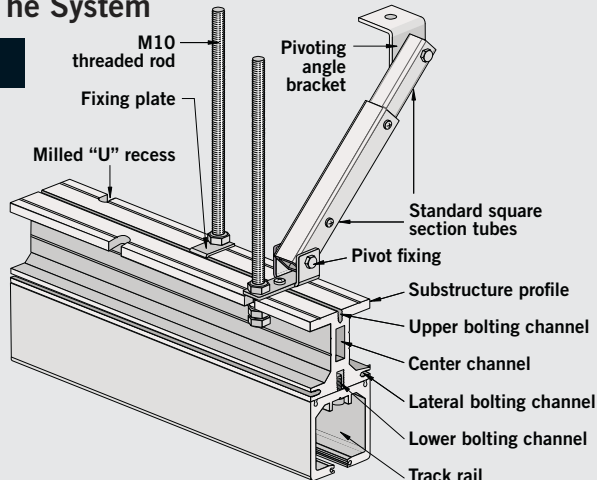

View from Above

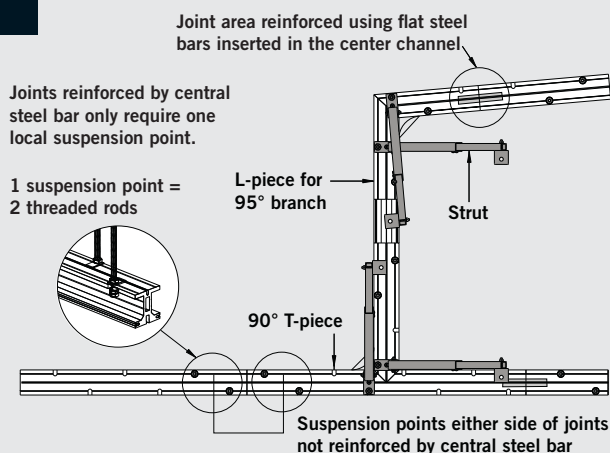

Example Load Values

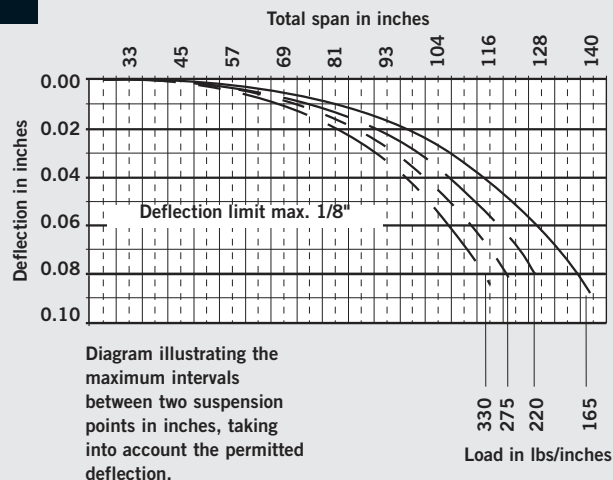

DORMA Glas, Inc.
1520 Jabez Run
Suite 303
Millersville, MD 21108
Tel: 410.923.0890
Toll Free: 800.451.0649
Fax 410.923.3060
E-mail: glas@dorma-usa.com
www.dorma-usa.com